

NX CAM-Only 5-Axis Machining

Benefits

- High-speed machining maximizes CNC machine investments
- Adaptive milling enables high material removal rates
- Smooth cutting pattern follows parts' natural shapes to deliver high quality surfaces
- Intelligent rest milling options allow associative multistage roughing techniques
- Master model capability ensures that NC programs stay associative to the source model
- Integrated postprocessor and Post Configurator provide production-ready output

Summary

NX™ CAM-Only 5-Axis Machining software provides a complete 5-axis milling package focused on machining any geometry with up to five axes of simultaneous motion. High-speed machining capabilities are provided as part of the full milling package.

2.5-axis milling and drilling

2.5-axis milling and drilling operations cover machining of prismatic parts using automated programming methods.

Flexible machining coordinate system

With NX CAM, you can make holes and planar cuts anywhere on the part, using any valid tool axis. These 2.5-axis cuts can be performed by 3+2 positional machines in any orientation.

Hole making

Extensive hole making functions are provided for spot drill, drill, ream bore and tap. You can use deep drill, peck drill and special boring cycles. User-defined cycles enable machining of any hole. Special multi-axis filtering automatically switches Machining Coordinate System for non-parallel hole selections.

Feature-based automation

You can take advantage of automatic feature processing that comes standard with NX. Feature recognition, process

application and tool selection functions automate machining of many features, including holes, pockets and slots.

Face milling

Solids-based face milling automatically respects part and fixture boundaries while efficiently clearing faces.

Boundary cutting

You can trace boundaries the traditional way with either edges or wireframe elements. You can individually specify offsets, compensation and other conditions for boundary elements. These boundaries serve as the basis for either single-trace cuts or area clearing patterns.

Generic motion control

You can build step-by-step tool motion with interactive drag handles and chain together cut traces with the most efficient transitions.

Probing cycles

NX CAM performs on-machine probing with the included Renishaw probing cycles for single-tip probes. You can measure faces, holes and bosses.

Generalized roughing

NX CAM roughs any generalized 3D shape with intelligent multilevel volume removal patterns and automatically cuts levels corresponding to horizontal faces. Area clearing patterns include zig, zig-zag, part or blank offsets.

High speed machining

NX provides an adaptive high-speed cutting strategy that helps you achieve a new level of machining efficiency.

NX CAM-Only 5-Axis Machining

The intelligent roughing method enables deep cuts and constant tool load that increases material removal rate.

Adaptive milling is ideal for cutting hard material, enabling significantly shorter machining cycles while extending tool life.

Z-level finishing

You can create z-level or waterline finishing passes on complex 3D geometry. Suitable for relatively steep areas, these cuts provide zig and zig-zag options with smooth engages, retracts and stepovers.

Rest machining

For re-roughing, NX CAM cuts only the areas untouched by previous roughing operations. You can use smaller tools only as needed for corner cleanout and use longer tools only as needed for deep reaches.

3-axis milling

3-axis milling provides extensive fixed-axis cutting capabilities for complex surfaces such as those found in mold and die applications. This functionality enables you to achieve the smoothest tool path results in steep areas by specifying a projection vector different from the tool axis.

Smooth raster cutting

You can output the smoothest raster or zig-zag cuts with special stepover moves and optimized point distribution to maintain high feed rates and fine finishes.

Smooth offset cutting

NX provides smooth offset pattern cuts with special stepover moves and corner treatments to maintain high feed rates and fine finishes. You can cut inside-out or outside-in.

Steep/non-steep area recognition

You can limit raster cuts to non-steep areas for better cut depth control, as well as provide consistent semi-finish cuts with combination z-level and raster fill-in patterns.

Interpolated passes

NX provides tool paths that flow organically with your part faces. With these smooth patterns, you can interpolate cutting passes between guide curves for the smoothest finishes. You can even cut true 3D spiral patterns with no stepover marks.

Automatic valley rest milling

NX discovers uncut valley material remaining from larger diameter tools, including bullnose tools. You can cut the remaining tools along or across valleys.

NURBS output

You can output non-uniform rational basis spline (NURBS) records for the smoothest machine motion and take advantage of high-level controller capabilities.

Facet machining

With NX CAM, you can use scanned data or other faceted representations such as .stl and the JT™ format for numerical control (NC) programming.

5-axis milling

5-axis milling provides extensive capabilities for simultaneous multi-axis cutting of complex surfaces, including multiple drive methods with a wide range of tool axis control options. 5-axis surface contouring and a set of tool axis interpolation options facilitate 5-axis machining on the most demanding of parts.

5-axis tool tip cutting

You can trace area patterns across complex geometry while specifying tool axis lead and lag relative to the surface normal.

5-axis roughing

This high-speed adaptive roughing method lets you get closer to the final shape using a minimum number of setups/operations. The adaptive milling

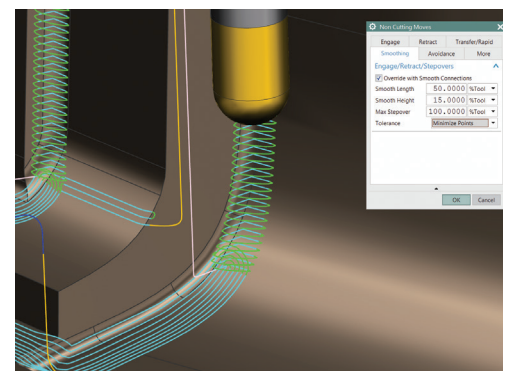
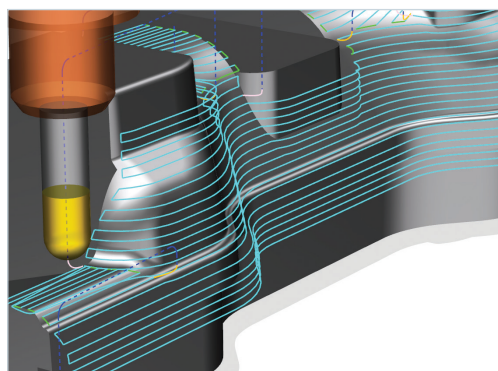
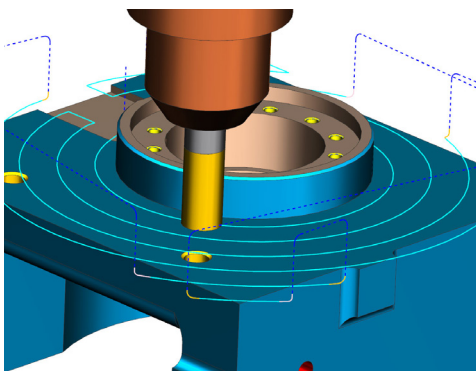

NX CAM benefits

- You can reduce setups with multi-axis milling
- Time-saving templates control cutting motion and tool axis with a minimum of user input
- User control makes it possible to program virtually any 5-axis cut

NX CAM features

- 5-axis surface area milling with lead/lag
- 5-axis roughing
- Contour profile provides swarf cutting
- Sequential mill provides cut-by-cut user control

strategy reduces heat generation and vibration in the cutting zone, which in turn reduces the wear of the cutting tools, extending tool life.

5-axis area patterns

All of the familiar 3-axis area clear patterns are provided with additional tool axis control. Raster cuts, offset patterns and interpolated cut strokes are all available.

5-axis swarf cutting

You can keep the side of the tool aligned with selected faces while controlling tilt.

Automatic 3-axis tilt

NX CAM invokes automatic tool tilt as a reaction to tool holder collisions in deep cavities. Tilting the tool over to provide clearance for the holder facilitates cutting with shorter tools and higher feed rates.

5-axis user control

NX CAM facilitates high levels of user controlled 5-axis milling. You can control multi-axis tool motion with traditional drive, part and check surface specifications. These flexible options make it possible to program virtually any 5-axis cut.

Machining simulation

The machining simulation capability provides a 3D model-based visualization of the planned machining operations. NX CAM facilitates multiple levels of simulation, ranging from a basic tool path verification to a full machining simulation that includes a complete machine tool model. Collision checking and multi-channel synchronization are simulated using the G-code for the most accurate results. With NX CAM, you can perform machine simulation from the programming environment so that information is at hand when you need it, avoiding the requirement for a separate machining simulation package for the NC programmer.

Tool path visualization

You can stay confident with tool path visualization and material removal verification tools. Integrated collision checking identifies any possible problems.

Tool path driven simulation

You can drive the machine simulation straight from internal tool path records for the fastest simulation result.

G-code driven simulation

NX CAM drives the machine simulation with postprocessed output that takes

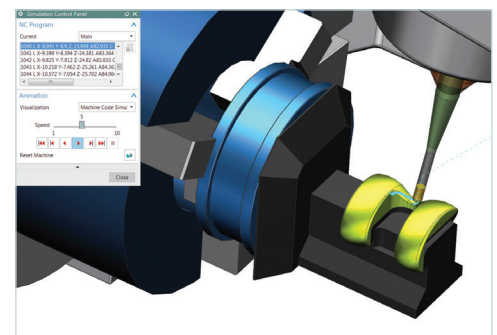
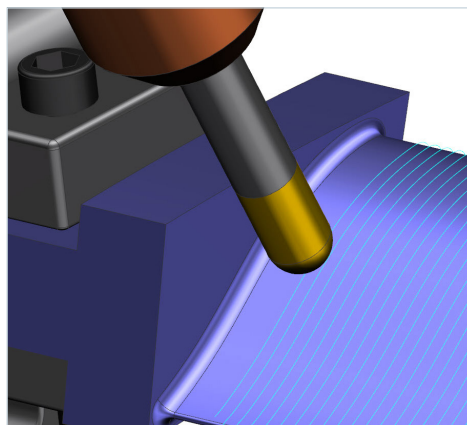
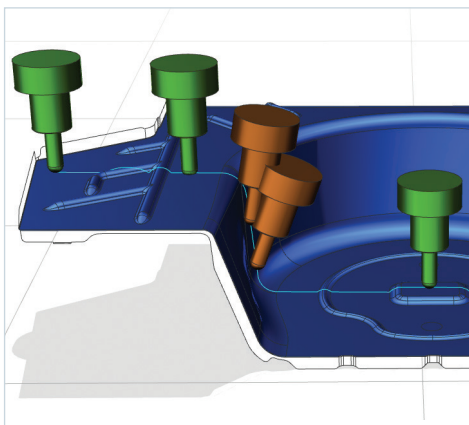

account of any program content provided by the postprocessor. Home positions, special tool change motion and other content can be inserted by the postprocessor, minimizing surprises by making sure to simulate the posted g-code.

Multichannel synchronization

NX shrinks cycle times for multichannel machines (multiple milling or drilling heads on the same machine) by optimizing synch codes. The visual system displays timelines and simulates multichannel motion to ensure that minimum cycles are achieved without interference.

Standard supporting functions

Translators

You can read data from practically any computer-aided design (CAD) system with a set of translators for the Parasolid® software, IGES, DXF and STEP and JT formats. In addition, you can write data in all of these formats, plus STL.

Operation navigator

From the computer-aided manufacturing (CAM) application's information center, you can create, view, modify, verify, inspect and organize your NC programs. You can manage tools, methods, geometry and output from an information-rich program display.

Tool path visualization

You can stay confident with tool path visualization and material removal verification tools. Integrated collision checking identifies any possible problems.

Tool path editing

You can make fast changes to tool path results with graphical editing tools and protect your edits by locking tool paths from future re-calculations.

CAM Templates

You can utilize the powerful template mechanism to create semi-automated processes customized to your

environment. Highly familiar operation dialogs help you to streamline common tasks with the minimum user input.

Postprocessing

NX outputs production-ready g-code via its integrated postprocessing. You can edit and fine-tune existing postprocessors with the included interactive post configurator application, or even build a postprocessor from scratch using post configurator templates. You can also use included sample posts or download a post from our support library.

Shop documentation

You can produce HTML setup documents with the included shop doc capability.

Feed rate optimization

NX CAM helps you to easily maximize material removal rates and minimize tool wear. The ability to adjust feed rates to achieve a specified chip volume eliminates overloading as well as underutilization of the cutting tool.

Standard model editing functions

NX CAM provides geometry tools to support common model editing functions that make NC programming more efficient. The standard range of functions provided are effective for making the kinds of changes to existing models that are sometimes needed in the NC programming context, such as altering a basic stock material shape. A set of more extensive CAD functions is available in the CAD/CAM version of this package to enable you to create/edit complex 3D part models and produce drawings.

Using the standard model editing functions, you can perform important model cleanup tasks with key editing capabilities for:

Associative geometry

You can associate copies of master geometry, enabling model editing without affecting the original design model.

3D wireframe construction for boundaries

Wireframe elements can be constructed from scratch or derived from part edges. Boundaries can be used directly for certain 2D operation types or used indirectly as containment boundaries to control tool path coverage.

Basic solid shapes

Solid blocks and cylinders can be created for use as blank models or fixture components.

Surface extensions and patches

You can patch over features that don't need to be machined. Tool paths will move smoothly across the patch, rather than trying to dig into the feature. You can extend faces to help guide tool tips around 3D edges if necessary.

Surface and edge extraction

Surfaces and edges can be extracted, divided, projected and used in various ways to more precisely support the needs of NC operations. For example, a divided surface provides an additional edge that can be used to drive or define toolpaths. Likewise, trim, sew and join functions enable surface and edges to be modified to support NC operations.

Synchronous modeling

Synchronous modeling, a powerful method for directly editing solid faces, is also available in the NC environment. Developing as-cast models or other derivatives from the existing parts is easy since the programmer simply needs to push and pull on the existing faces.

Assembly modeling

NX CAM includes important fixture components in the programming session, while facilitating intelligent collision avoidance. Our master model concept keeps the assemblies and tool paths associative to your source model. NX assembly design supports "top-down" and "bottom-up" approaches,

while enabling you to rapidly navigate the assembly hierarchy with direct access to the design model of any component or subassembly.

Available add-ons

You can configure the perfect CAM seat by adding the tool path creation options that your programs require. You can choose from:

- Turning
- Wire EDM
- Feature-based machining author
- Turbomachinery milling

Available Teamcenter integration

You can integrate NX CAM with Teamcenter® software by including the NX CAM Teamcenter Client add-on. This integration provides a managed environment for your NX data. Additional Teamcenter functionality is available separately.

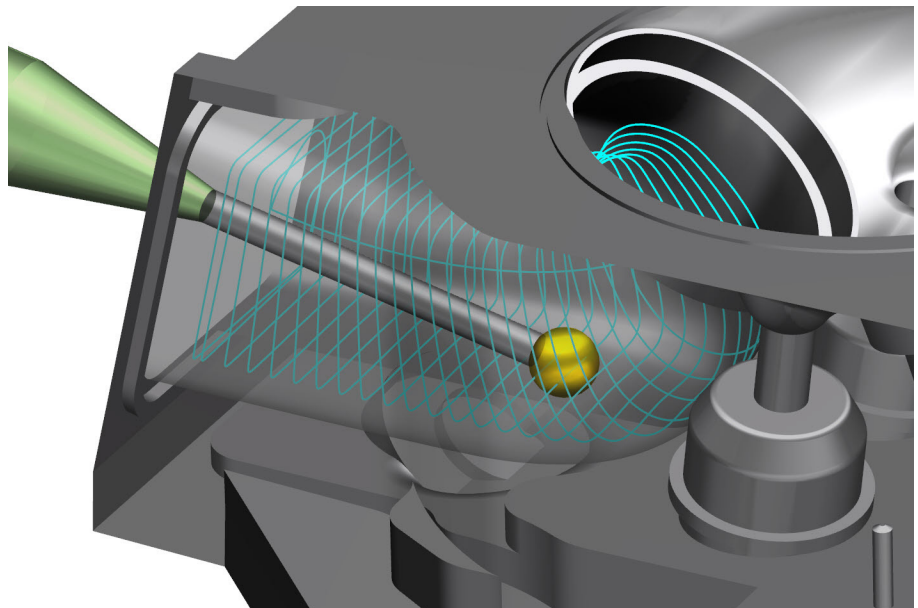
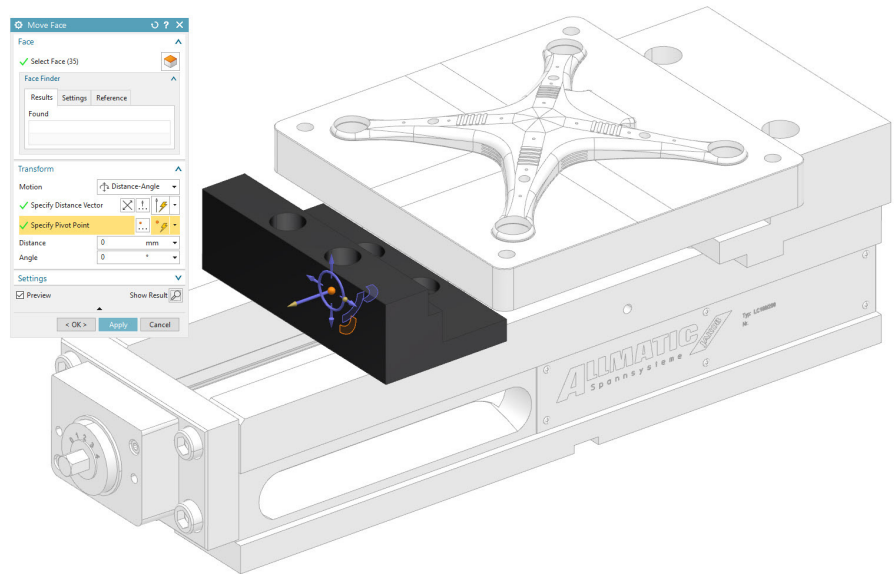

Siemens Digital Industries Software
siemens.com/software

Americas +1 314 264 8499
Europe +44 (0) 1276 413200
Asia-Pacific +852 2230 3333