

NX Advanced 5-Axis Machining

Benefits

- High-speed machining maximizes CNC machine investments
- 3- and 5-axis adaptive milling enables high material removal rates
- Smooth cutting pattern for high quality surfaces
- Feature-based machining automates programming and improves productivity
- Master model capability ensures that NC programs stay associative to the source model
- Integrated postprocessor provides production-ready output

Summary

NX™ Advanced 5-Axis Machining software provides a complete computer-aided design/computer-aided manufacturing (CAD/CAM) package to program any part geometry. High-speed machining and 5-axis simultaneous milling capabilities are provided along with advanced CAD capabilities.

2.5-axis milling and drilling

2.5-axis milling and drilling operations cover machining of prismatic parts using automated programming methods.

Flexible machining coordinate system (MCS)

With NX CAM, you can make holes and planar cuts anywhere on the part using any valid tool axis. It enables 2.5-axis operations to be performed on 3+2 positional machines in any orientation.

Hole making

Extensive hole making functions are provided for spot drill, drill, ream bore and tap. You can use deep drill, peck drill and special boring cycles. User-defined cycles enable machining of any hole. Special multi-axis filtering automatically switches MCS for non-parallel hole selections.

Feature-based automation

You can take advantage of automatic feature processing that comes standard with NX. Feature recognition, process application and tool selection functions automate machining of many features, including holes, pockets and slots.

Face milling

Solids-based face milling automatically categorizes the part and fixture, enabling easy programming and safe machining.

Generic motion control

You can build step-by-step tool motion with interactive drag handles and chain together cut traces with the most efficient transitions.

Probing cycles

NX CAM performs on-machine probing with the included Renishaw probing cycles for single-tip probes. You can measure faces, holes and bosses.

Generalized roughing

NX CAM roughs any generalized 3D shape with intelligent multilevel volume removal patterns and automatically cuts levels corresponding to horizontal faces. Area-clearing patterns include zig, zig-zag, part or blank offsets.

NX Advanced 5-Axis Machining

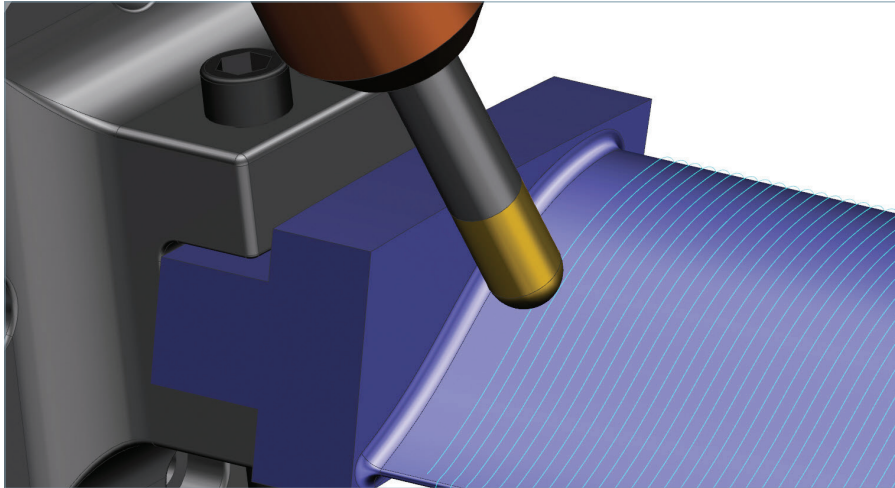

High-speed machining (HSM)

NX provides adaptive high-speed cutting strategies that help you achieve a new level of machining efficiency. Adaptive milling, an advanced roughing method, enables deep cuts and consistent tool load, resulting in high material removal rates. Ideal for cutting hard material, enabling a significantly shorter machining cycle while extending tool life.

Z-level finishing

You can create z-level or waterline finishing passes on complex 3D geometry. Suitable for relatively steep areas, these cuts provide zig and zig-zag options with smooth engages, retracts and stepovers.

Rest machining

For re-roughing, NX CAM cuts only the areas untouched by previous roughing operations. You can use smaller tools only as needed for corner cleanout and longer tools for deep reaches.

3-axis milling

3-axis milling provides extensive fixed-axis cutting capabilities for complex surfaces such as those found in mold and die applications. This functionality enables you to achieve the smoothest toolpath results in steep areas by specifying a projection vector different from the tool axis.

Independent projection vector

NX CAM enables you to achieve the smoothest toolpath results in steep areas by specifying a projection vector different from the tool axis.

Smooth raster cutting

You can output the smoothest raster or zig-zag cuts with special stepover moves and optimized point distribution to maintain high feed rates and fine finishes.

Smooth offset cutting

NX provides smooth offset pattern cuts with special stepover moves and corner treatments to maintain high feed rates and fine finishes. You can cut inside-out or outside-in.

Steep/nonsteep area recognition

You can limit raster cuts to nonsteep areas for better cut depth control, as well as provide consistent semifinish cuts with combination z-level and raster fill-in patterns.

Interpolated passes

NX provides toolpaths that flow organically with your part faces. With these smooth patterns, you can interpolate guide curves for the smoothest finishes. You can even cut true 3D spiral patterns with no stepover marks.

Automatic valley rest milling

NX discovers uncut valley material remaining from larger diameter tools, including bullnose tools. You can cut the remaining tools along or across valleys.

NURBS output

You can output non-uniform rational basis spline (NURBS) records for the smoothest machine motion and take advantage of high-level controller capabilities.

Facet machining

With NX CAM, you can use scanned data or other faceted representations such as .stl and the JT™ data format for numerical control (NC) programming.



Features

- 3- and 5-axis adaptive roughing
- 5-axis surface area milling with lead/lag
- Contour profile provides swarf cutting
- Sequential mill provides cut-by-cut user control
- Turbomachinery milling for multiblade geometry

5-axis milling

5-axis milling provides extensive capabilities for simultaneous multi-axis cutting of complex surfaces, including multiple drive methods with a wide range of tool axis control options. 5-axis surface contouring and a set of tool axis interpolation options facilitate 5-axis machining on the most demanding of parts.

5-axis roughing

This high-speed adaptive roughing method lets you get closer to the final shape using a minimum number of setups/operations. The adaptive milling strategy reduces heat generation and vibration in the cutting zone, which in turn reduces the wear of the cutting tools and extends tool life.

5-axis tool tip cutting

You can trace area patterns across complex geometry while specifying tool axis lead and lag relative to the surface normal.

5-axis area patterns

All of the familiar 3-axis area clear patterns are provided with additional tool axis control. Raster cuts, offset patterns and interpolated cut strokes are all available.

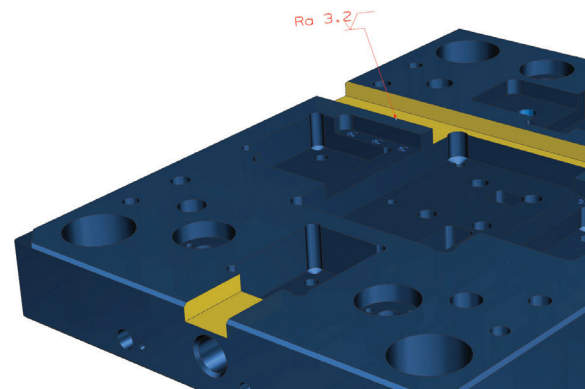

5-axis swarf cutting

You can keep the side of the tool aligned with selected faces while controlling tilt.

Automatic 3-axis tilt

NX CAM invokes automatic tool tilt as a reaction to tool holder collisions in deep cavities. Tilting the tool over to provide clearance for the holder facilitates cutting with shorter tools and higher feed rates.

Turbomachinery milling

NX CAM optimizes programming for turbomachinery configurations, including multibladed turbines and blisks. Special operations for roughing and finishing blades and hubs maintain clearances even in the tightest blade configurations. Geometry inputs allow for imperfect and unstitched selections without slowing down the programmer with geometry repair.

5-axis user control

NX CAM includes high levels of user-controlled 5-axis milling. You can control multi-axis tool motion with traditional drive, part and check surface specifications. These flexible options make it possible to program virtually any 5-axis cut.

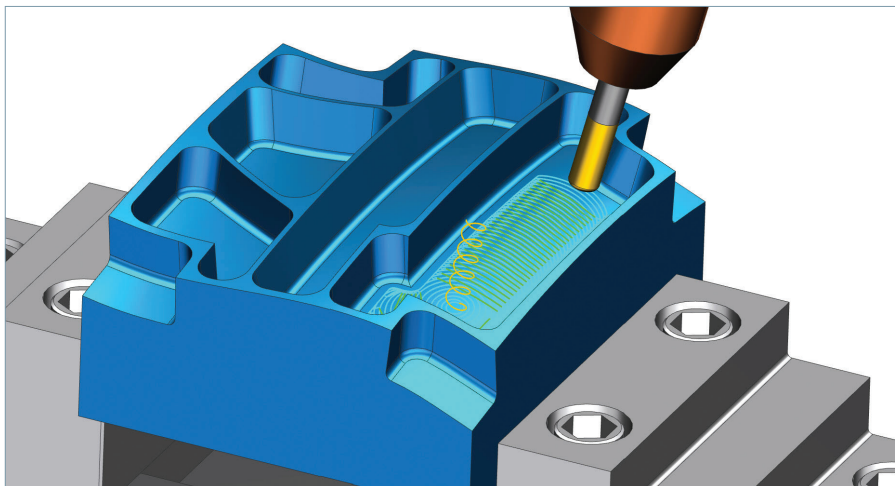

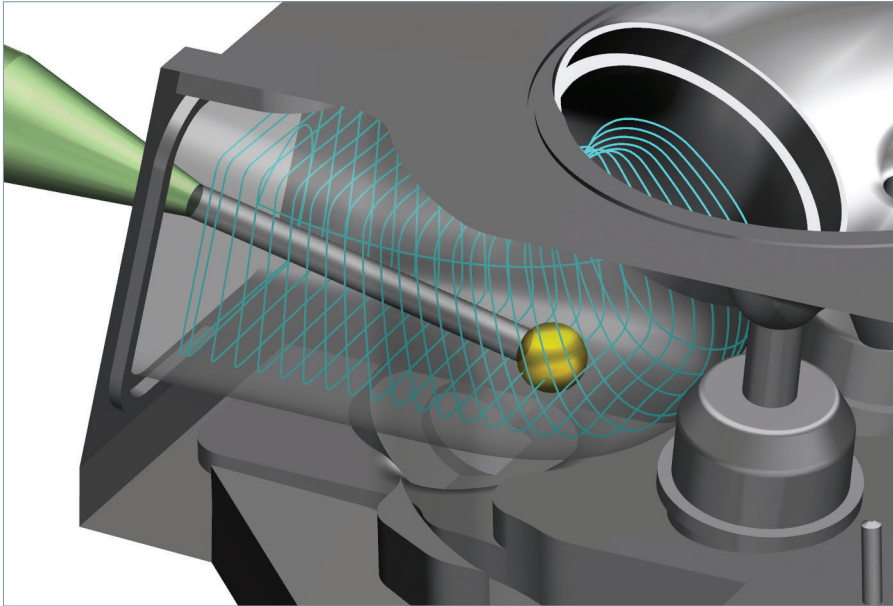

Machining simulation

The machining simulation capability provides a 3D model-based visualization of the planned machining operations. NX CAM facilitates multiple levels of simulation from a basic toolpath verification to a full machining simulation that includes a complete machine tool model. Collision checking and multichannel synchronization are simulated at the g-code level for the most accurate results. With NX CAM, you can perform machine simulation right from the programming environment so information is at hand when you need it, avoiding the requirement for a separate machining simulation package for the NC programmer.

Toolpath driven simulation

You can drive the machine simulation straight from internal toolpath records for the fastest simulation result.

G-code driven simulation

NX CAM drives the machine simulation with postprocessed output that takes account of any program content provided by the postprocessor. Home positions, special tool change motion and other content can be inserted by the postprocessor, minimizing surprises by making sure to simulate the posted g-code.

Multichannel synchronization

NX helps shrink cycle times for multichannel machines (multiple milling or drilling heads on the same machine) by optimizing synch codes. The visual system displays timelines and simulates multichannel motion to ensure that minimum cycles are achieved without interference.

Standard supporting functions

Translators

You can read data from practically any CAD system with a set of translators for the Parasolid® software, Initial Graphics Exchange Specification (IGES), Drawing eXchange Format (DXF), Standard for the Exchange of Product Data (STEP) and the JT data formats. In addition, you can write data in all of these formats, plus stereolithography (STL).

Operation navigator

From the CAM application's information center, you can create, view, modify, verify, inspect and organize your NC programs. You can manage tools, methods, geometry and output from an information-rich program display.

Toolpath visualization

You can stay confident with toolpath visualization and material removal verification tools. Integrated collision checking identifies any possible problems.

Toolpath editing

You can make fast changes to toolpath results with graphical editing tools and protect your edits by locking toolpaths from future re-calculations.



CAM templates

You can utilize the powerful template mechanism to create semi-automated processes customized to your environment. Highly familiar operation dialogs help you streamline common tasks with minimum user input.

Postprocessing

NX outputs production-ready g-code via its integrated postprocessing. You can edit and fine-tune existing postprocessors with the included interactive Post Configurator application, or even build a postprocessor from scratch using Post Configurator templates. You can also use included sample posts or download a post from our support library.

Shop documentation

You can produce HTML setup documents with the included shop doc capability.

Feed rate optimization

NX CAM helps you easily maximize material removal rates and minimize tool wear. The ability to adjust feed rates to achieve a specified chip volume eliminates overloading as well as under utilization of the cutting tool.

Standard model editing functions

NX CAM provides design tools to address common model editing functions that make NC programming more efficient. The standard range of provided functions are effective for making the kinds of changes to existing models that are often needed in the NC programming context, such as altering a basic stock material shape. Using the standard model editing functions, you can perform important model cleanup tasks with key editing capabilities for the following:

Associative geometry

You can create associate copies of master geometry, enabling model editing without affecting the original design model.

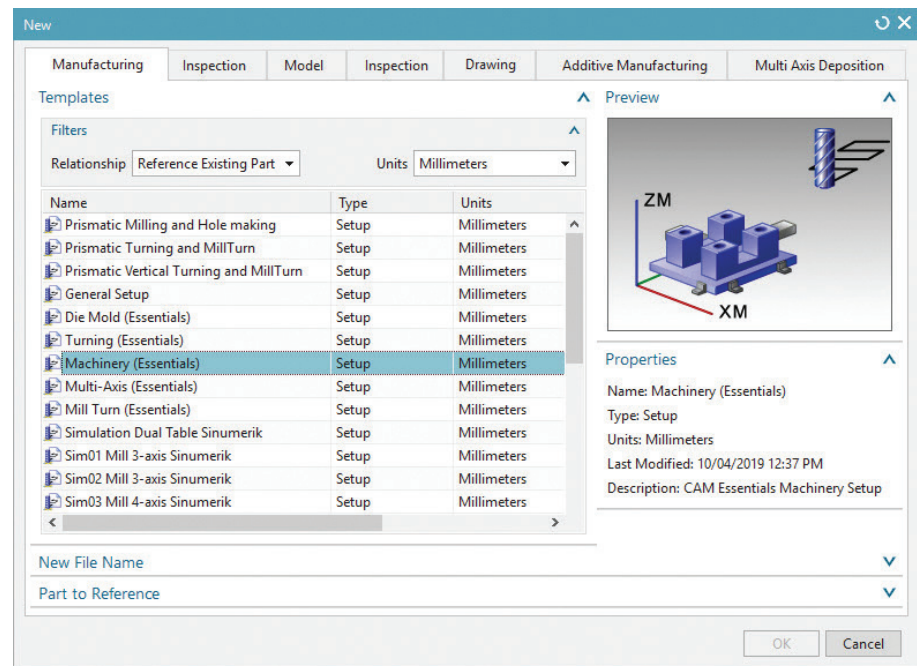

3D wireframe construction for boundaries

Wireframe elements can be constructed from scratch or derived from part edges. Boundaries can be used directly for certain 2D operation types or used indirectly as containment boundaries to control toolpath coverage.

Basic solid shapes

Solid blocks and cylinders can be created for use as blank models or fixture components.

Surface extensions and patches

You can patch over features that don't need to be machined. Toolpaths will move smoothly across the patch, rather than try to dig into the feature. You can extend faces to help guide tool tips around 3D edges, if necessary.

Surface and edge extraction

Surfaces and edges can be extracted, divided, projected and used in various ways to more precisely support the needs of NC operations. For example, a divided surface provides an additional

edge that can be used to drive or define toolpaths. Likewise, trim, sew and join functions enable surface and edges to be modified to support NC operations.

Synchronous modeling

Synchronous modeling, a powerful method for directly editing solid faces, is also available in the NC environment. Developing as-cast models or other derivatives from the existing parts is easy since the programmer simply needs to push and pull on the existing faces.

Assembly modeling

NX CAM includes important fixture components in the programming session and provides intelligent collision avoidance. Our master model concept keeps the assemblies and toolpaths associative to your source model. NX assembly design supports "top-down" and "bottom-up" approaches and provides rapid navigation of the assembly hierarchy with direct access to the design model of any component or subassembly.

Extended CAD content included with the CAD/CAM package

The standard CAM version of the CAD/CAM package provides geometry tools to address common model editing functions. A set of more extensive CAD functions (described below) is available in the CAD/CAM version of this package that enable you to create and edit complex 3D part models and produce drawings. The combination of CAD and CAM in one system provides one of the most fully integrated solid modeling systems available today.

Drafting

You can create engineering drawings that remain associative to your part models, including automatic view creation from solids, hidden line processing and automated parts lists. You can use templates to automatically create drawings for borders and view layouts.

Solid modeling

Using the CAD/CAM integration provided in NX Advanced 5-Axis Machining, you can develop 3D models with a full range of synchronous modeling and parametric modeling tools, including wireframe, primitives, swept and revolved bodies. Boolean operation and associative editing are supported. You can provide details such as blends, tapers and thin-wall features. NX modeling is powered by synchronous technology, Siemens Digital Industries Software's unique approach to 3D design that combines the power of parametric feature-based modeling with the freedom of history-free modeling.

User-defined features

Integrated CAD/CAM capabilities let you capture and store families of features for easy retrieval and editing, starting with existing associative solid models. You can establish relationships between parameters, define feature variables, set default values and decide the general form that the feature will take when started.

Basic surfacing

You can create complex surfaces and solid models using loft and sweep techniques, including multirail methods. You can also fine-tune surfaces with surface extension and surface normal control.

Sheet metal

With the included sheet metal capabilities, you can create sheet metal component models using feature-based design tools for tabs, flanges and other typical features. You can use forming tables and bend sequence tables to account for bend deformation and generate accurate flat pattern data for manufacturing.

Associativity

You can absorb changes with ease with a fully integrated CAD/CAM system that keeps the NC program connected to the design model and updates to new geometry.

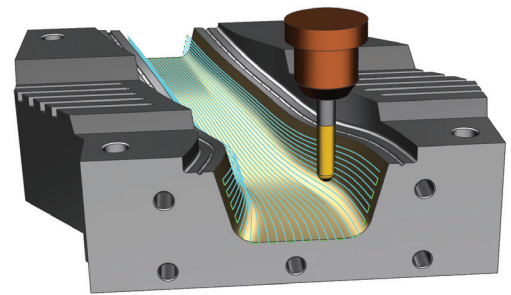

Available add-ons

You can configure the perfect CAM seat by adding the toolpath creation options that your programs require. You can choose from:

- Turning
- Wire electrical discharge machining (EDM)
- Feature-based machining author

Available Teamcenter integration

You can integrate NX CAM with Teamcenter® software by including the NX CAM Teamcenter Client add-on. This integration provides a managed environment for your NX data. Additional Teamcenter functionality is available separately.

Siemens Digital Industries Software
[siemens.com/software](https://www.siemens.com/software)

Americas +1 314 264 8499
 Europe +44 (0) 1276 413200
 Asia-Pacific +852 2230 3333